

VANILLA

**Robot chassis &
autonomous
remote control**

tomas krivda tomas@vanilla.cz
jan sedlacek jan@vanilla.cz

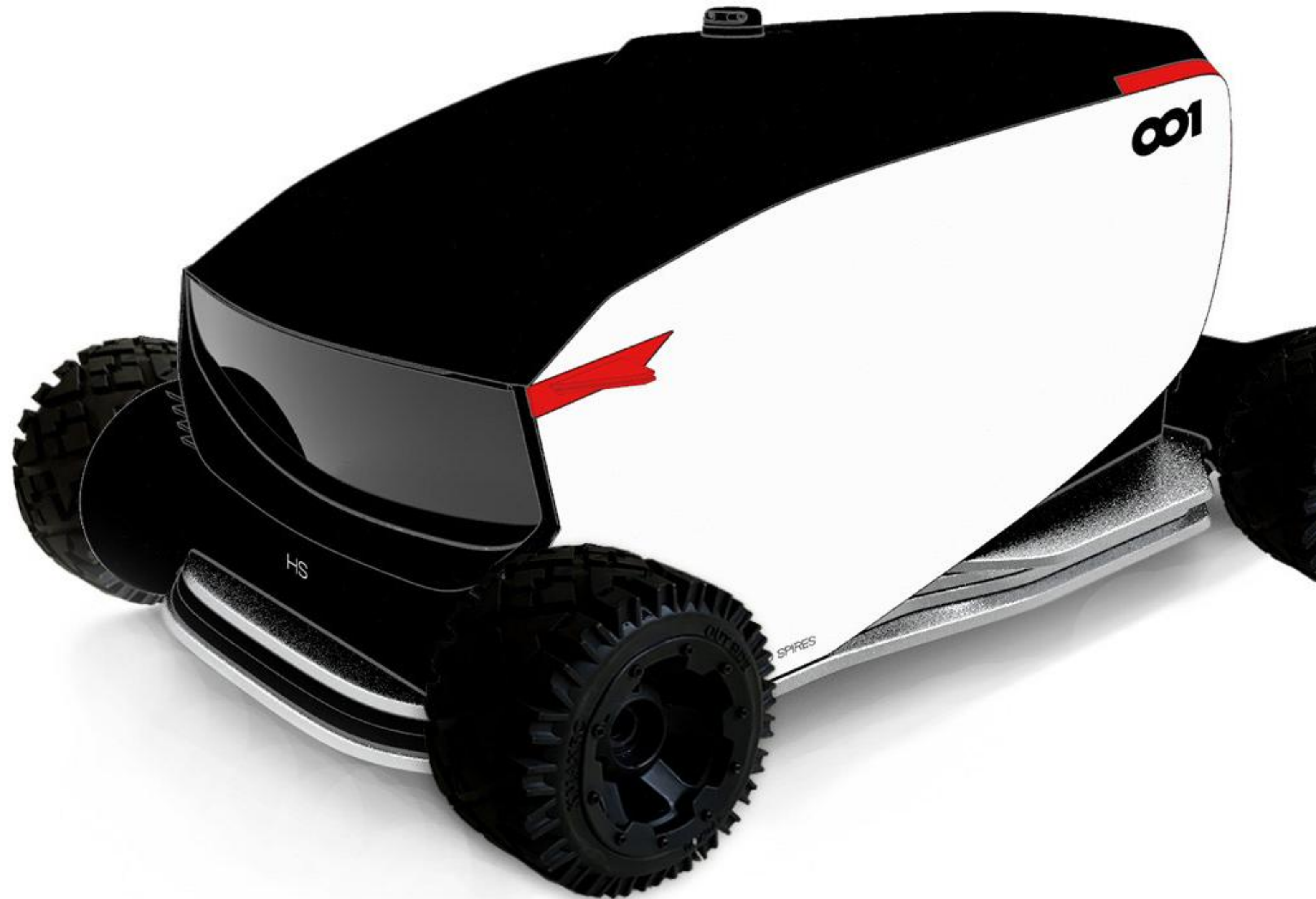

HARDWARE

single 2KW brushless motor
VESC motor controller
4 wheel drive
nvidia jetson nano aarch64
intel t265 & d455
rpi lidar / velodyne / luminar
LTE/5G network
60Ah lithium ion 12/24V
rtk gps

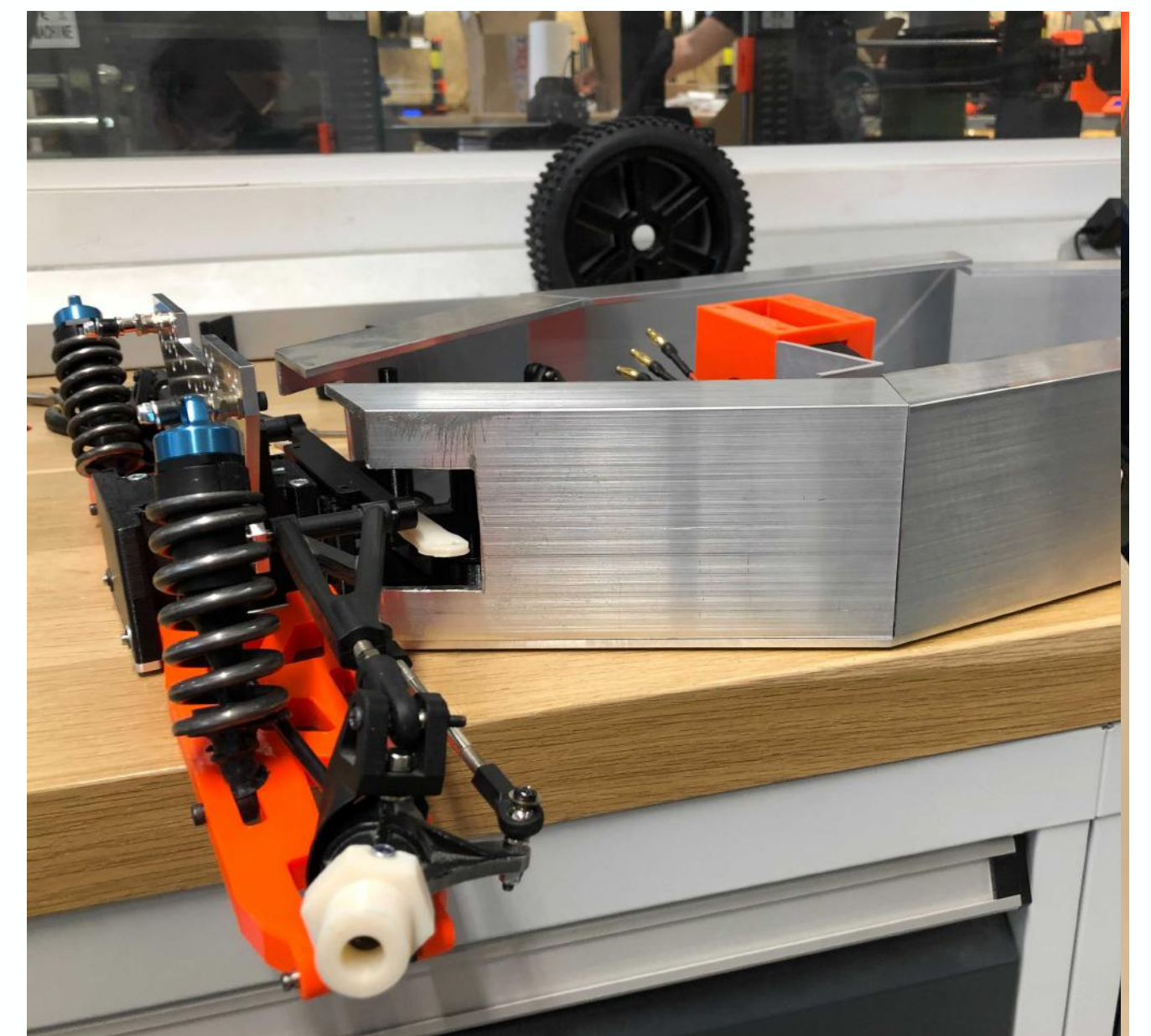
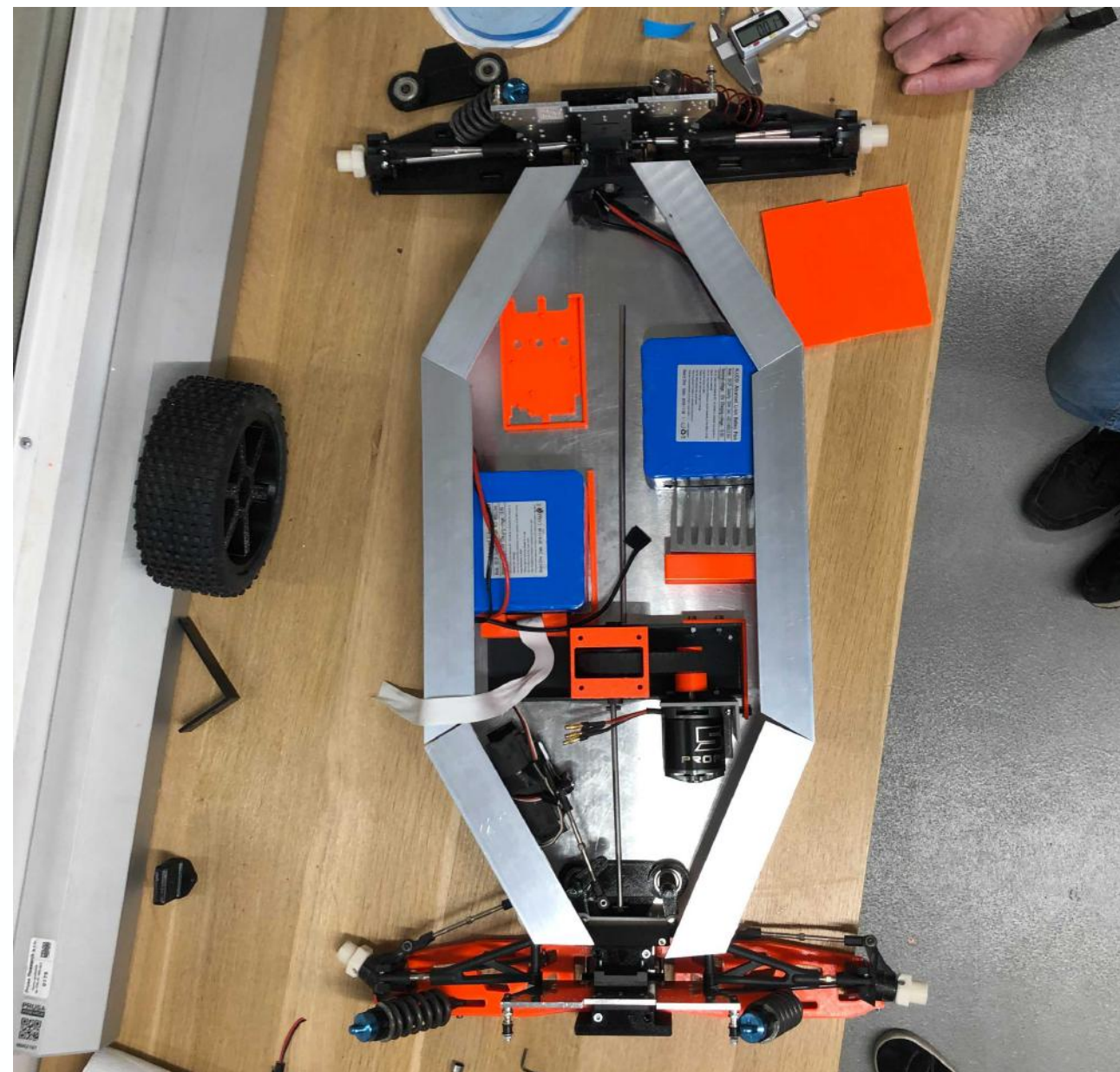
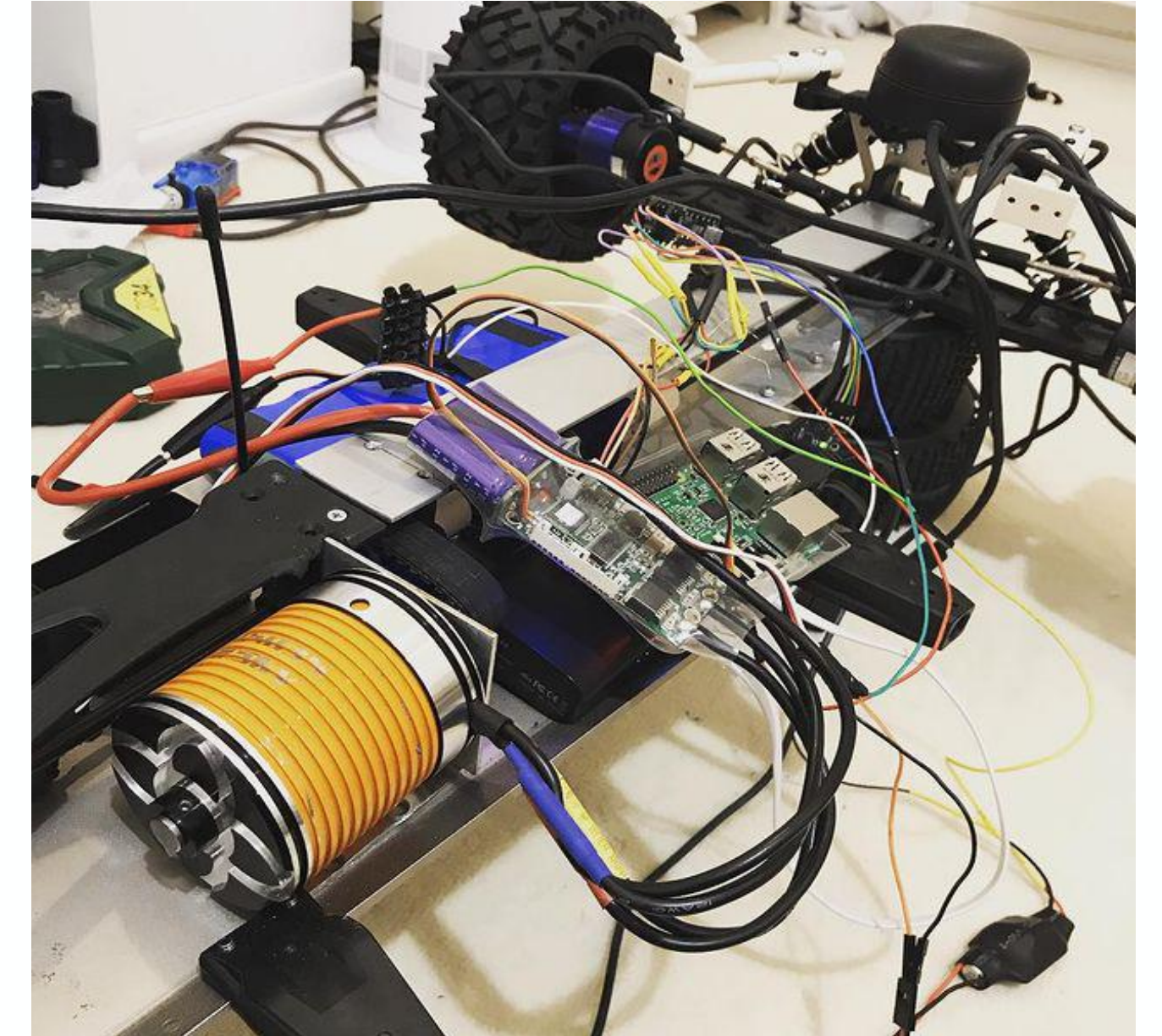



Concept
ROBOT PROTOTYPE

POINTCLOUD

Navigation & localization

The robots are capable to navigate around neighbourhoods carrying up to 20kg payloads or equipment within blocks of cities and safely avoid and detect obstacles in their paths created from occupancy map

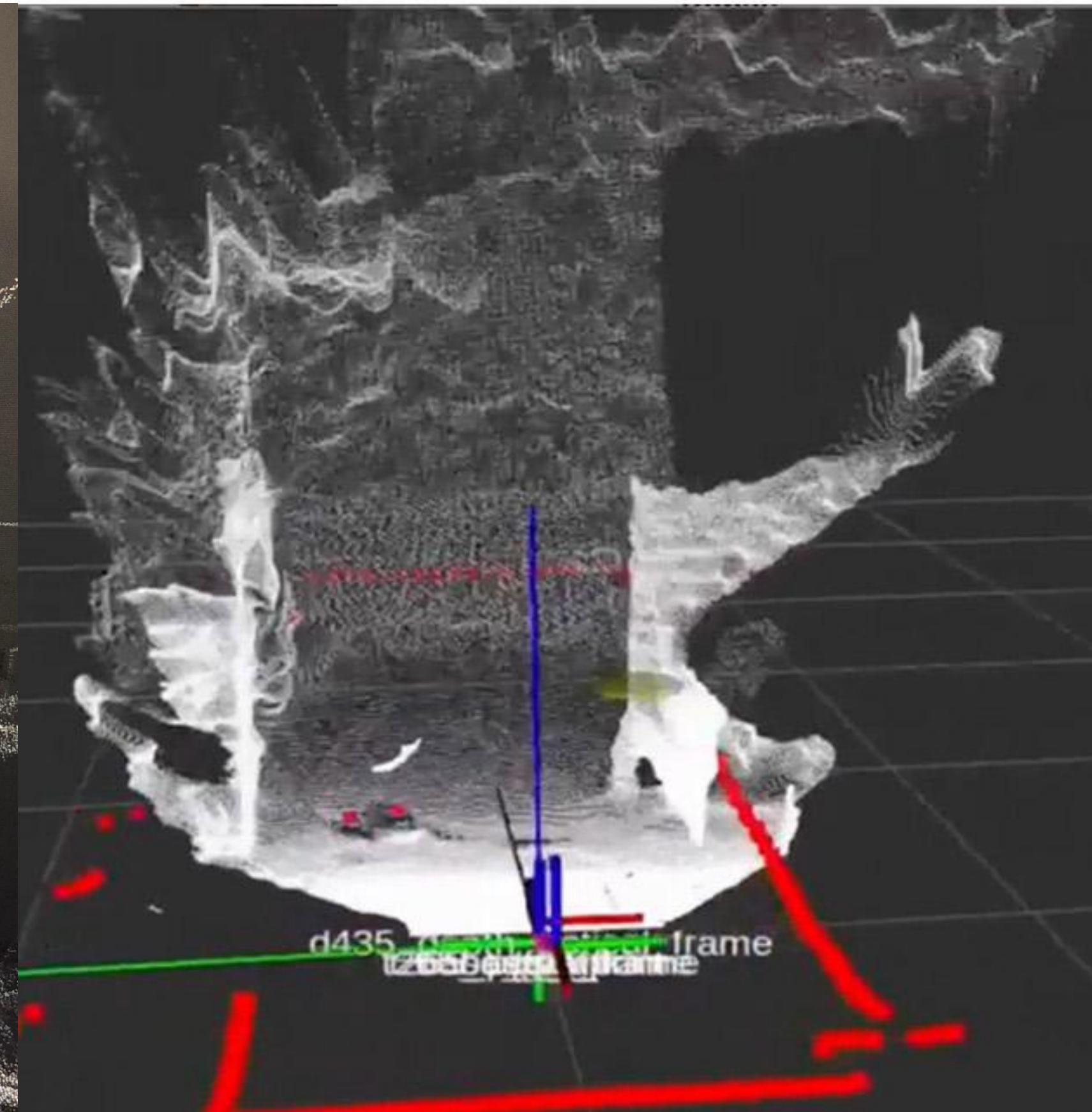

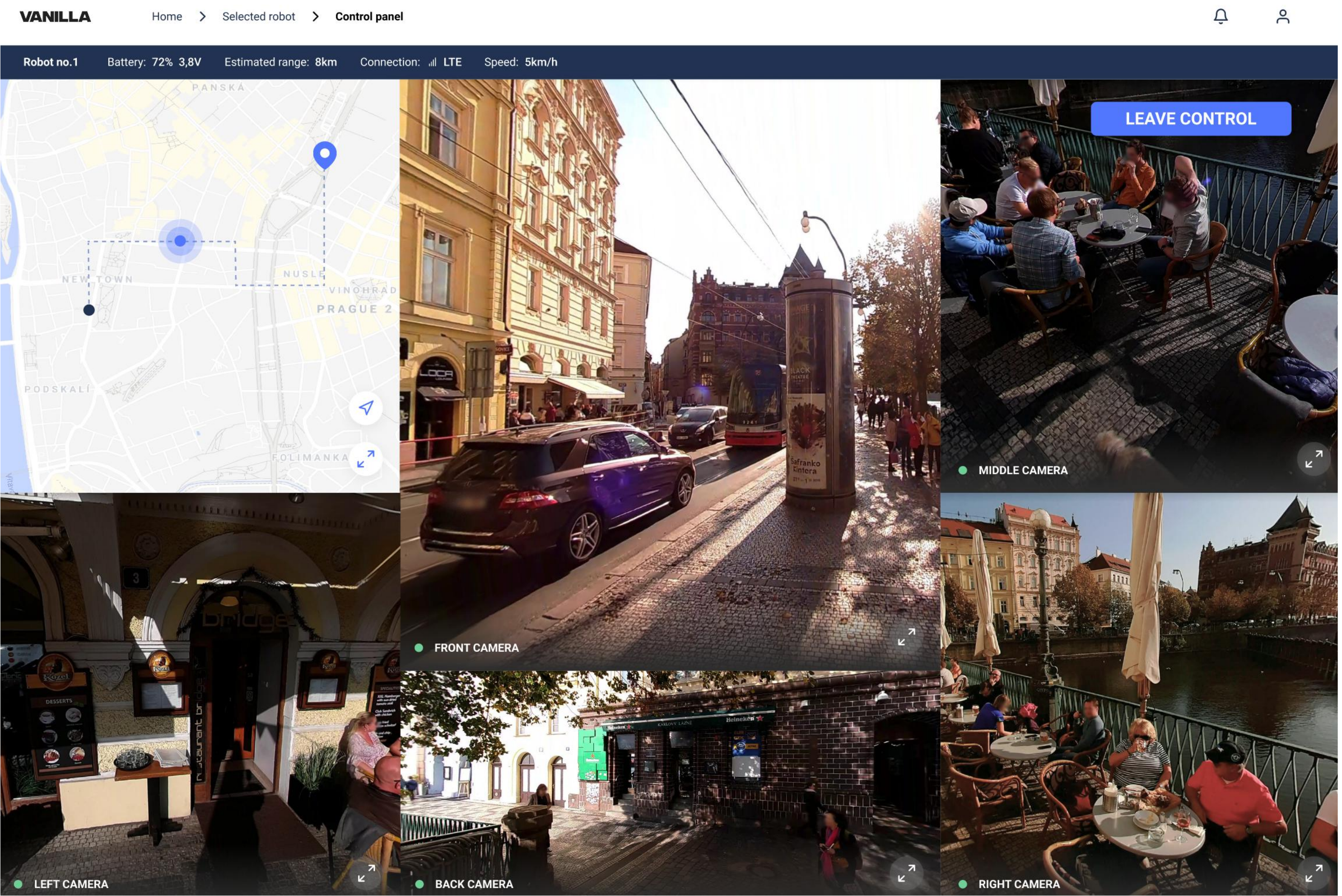

Remote control

ROS - robotic operating system
 Global and Local Path Planning
 ORB SLAM / Autoware
 iOS mac / ipad apps for remote control

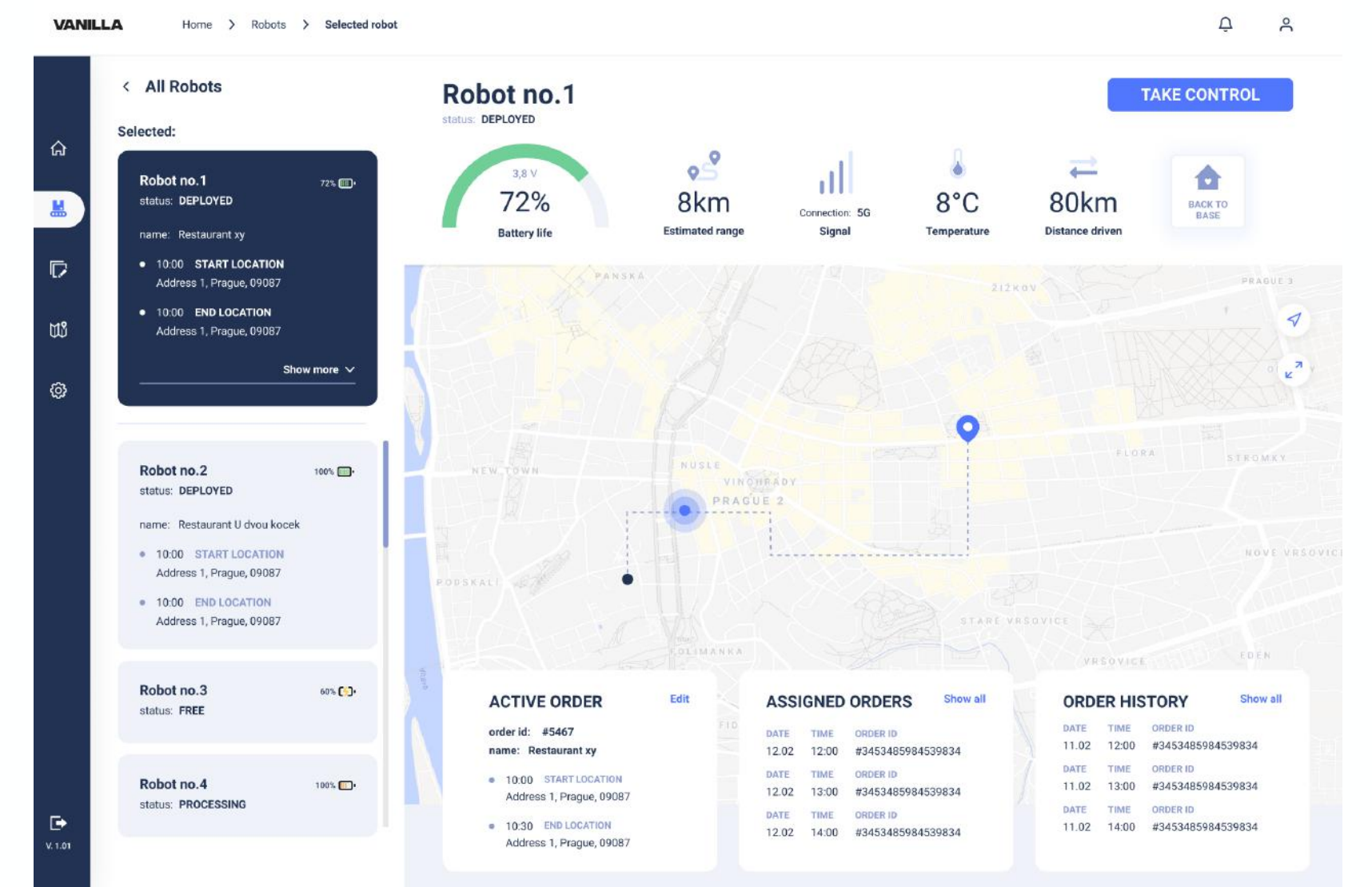

autoware & orb slam

MOBILE / WEB APPS / API / CANBUS CONNECTION

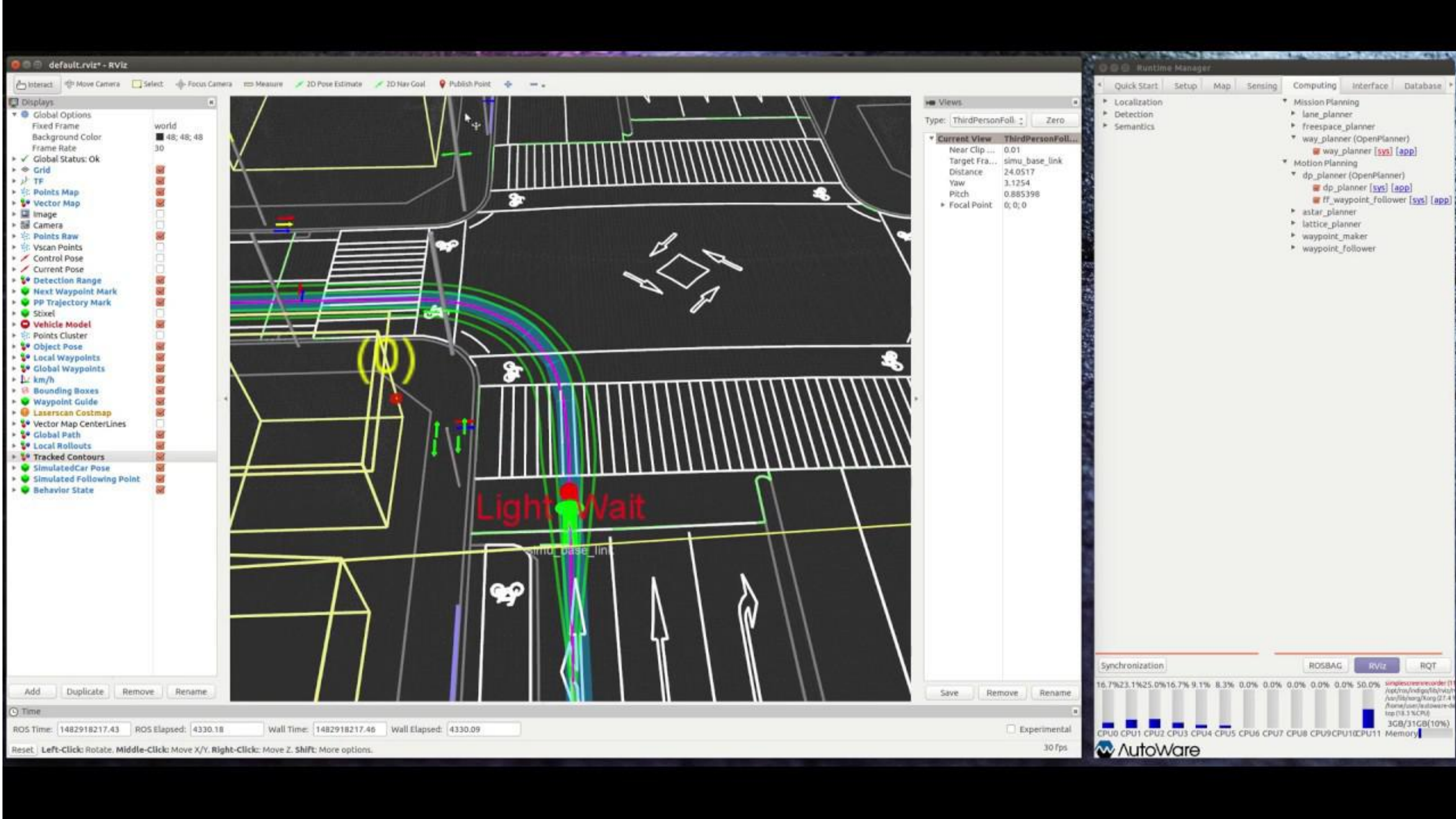
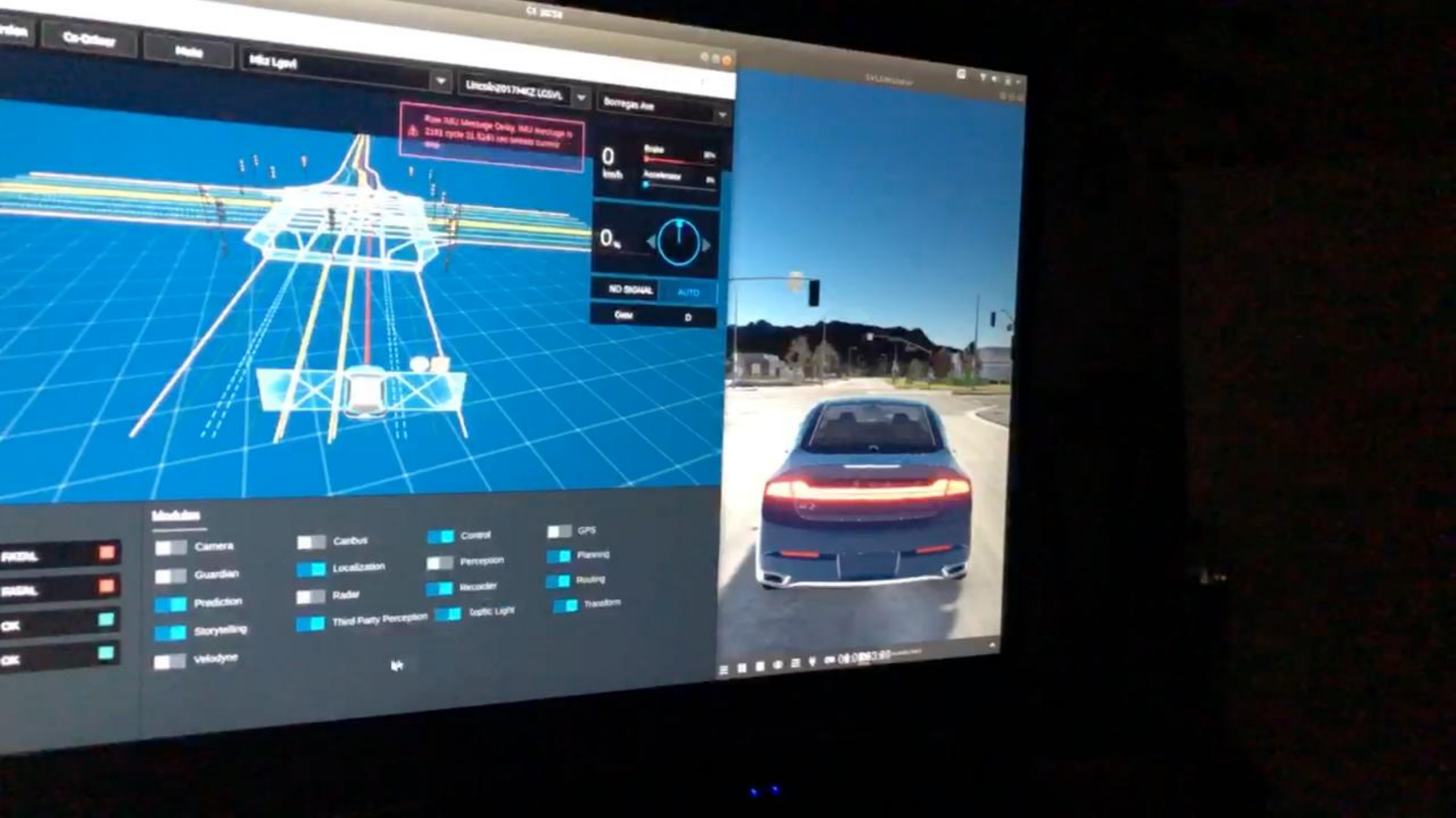
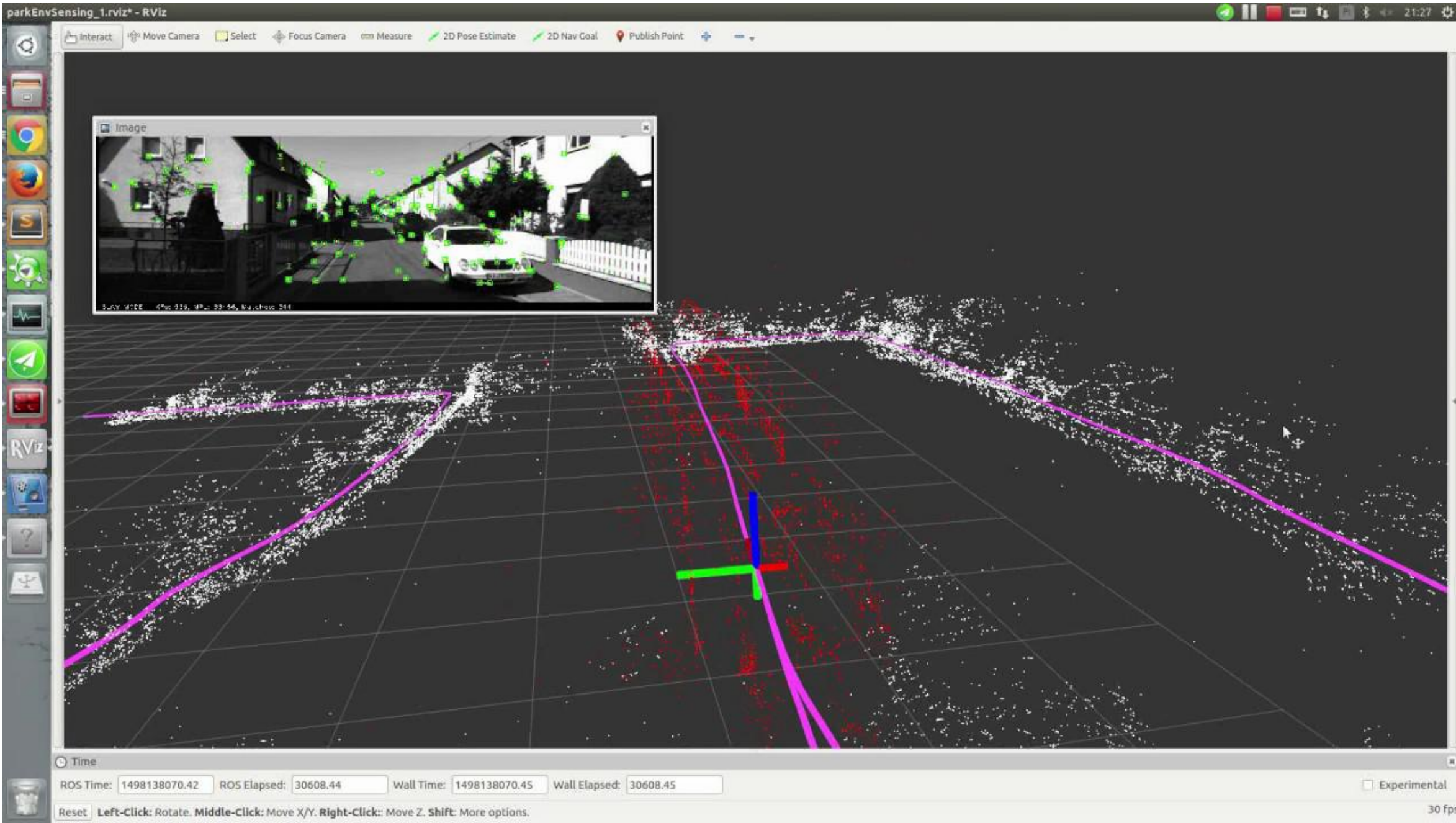

LAST MILE DELIVERY COMPETITION

starship technologies
amazon deliveries
postmates

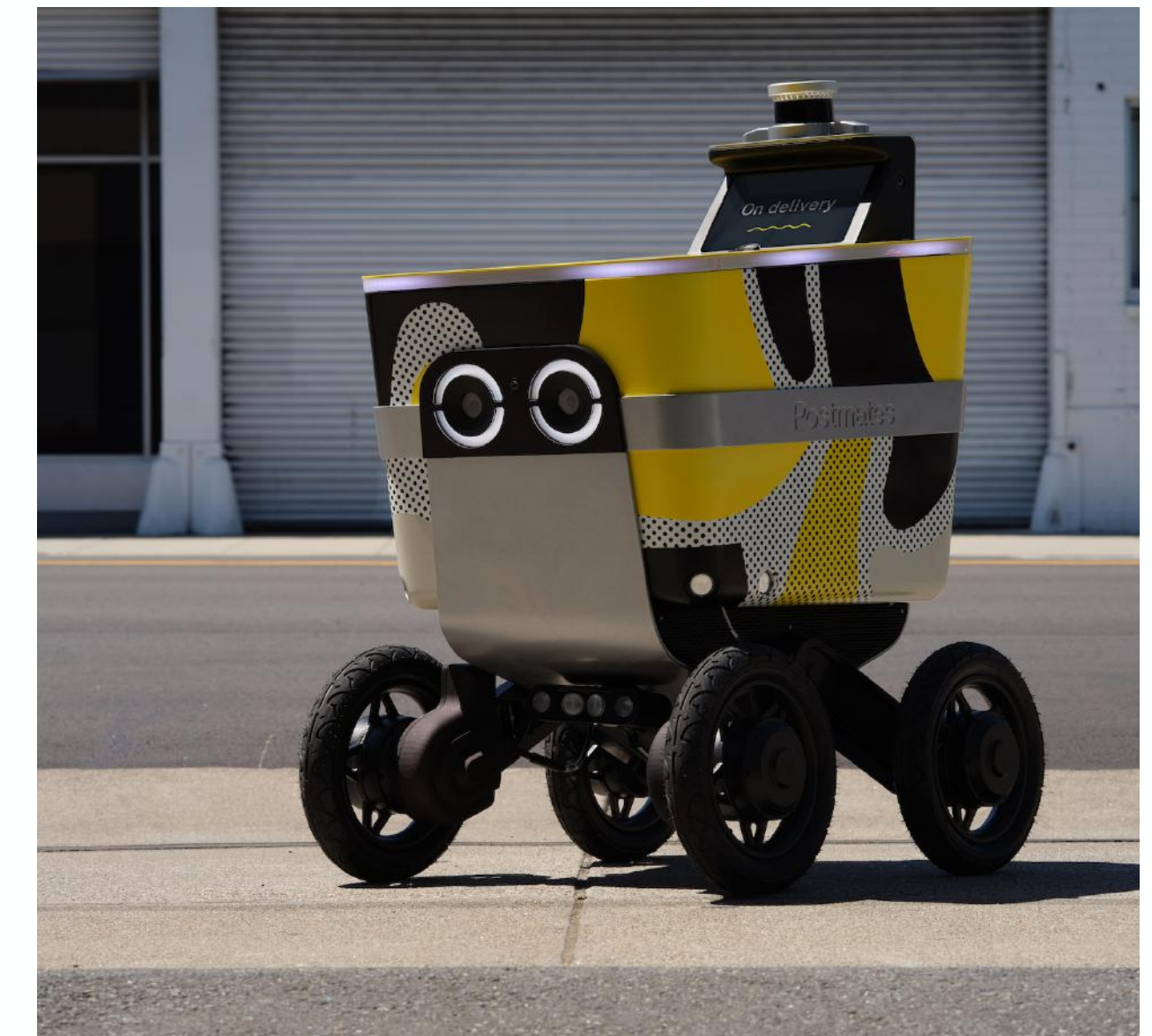

3D DESIGNS

vision

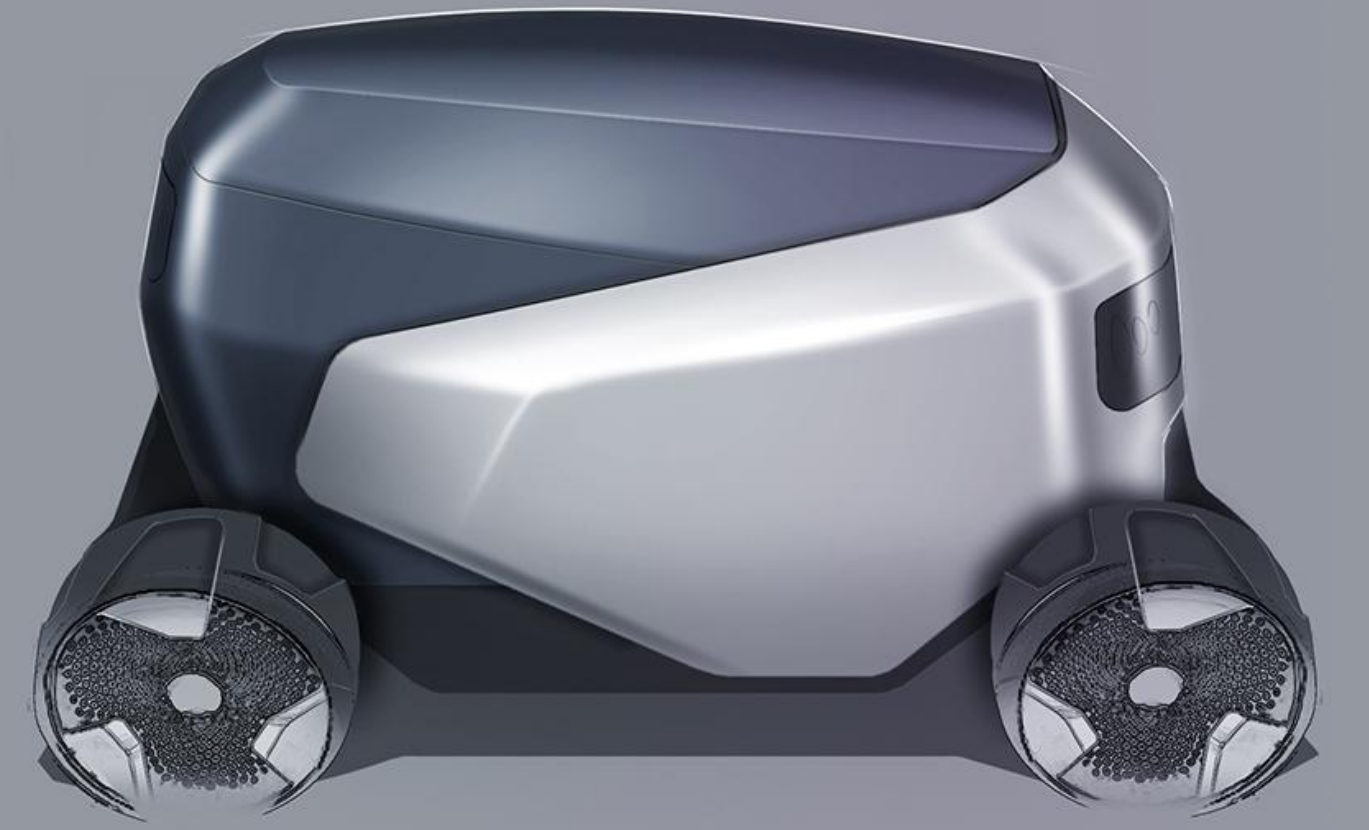
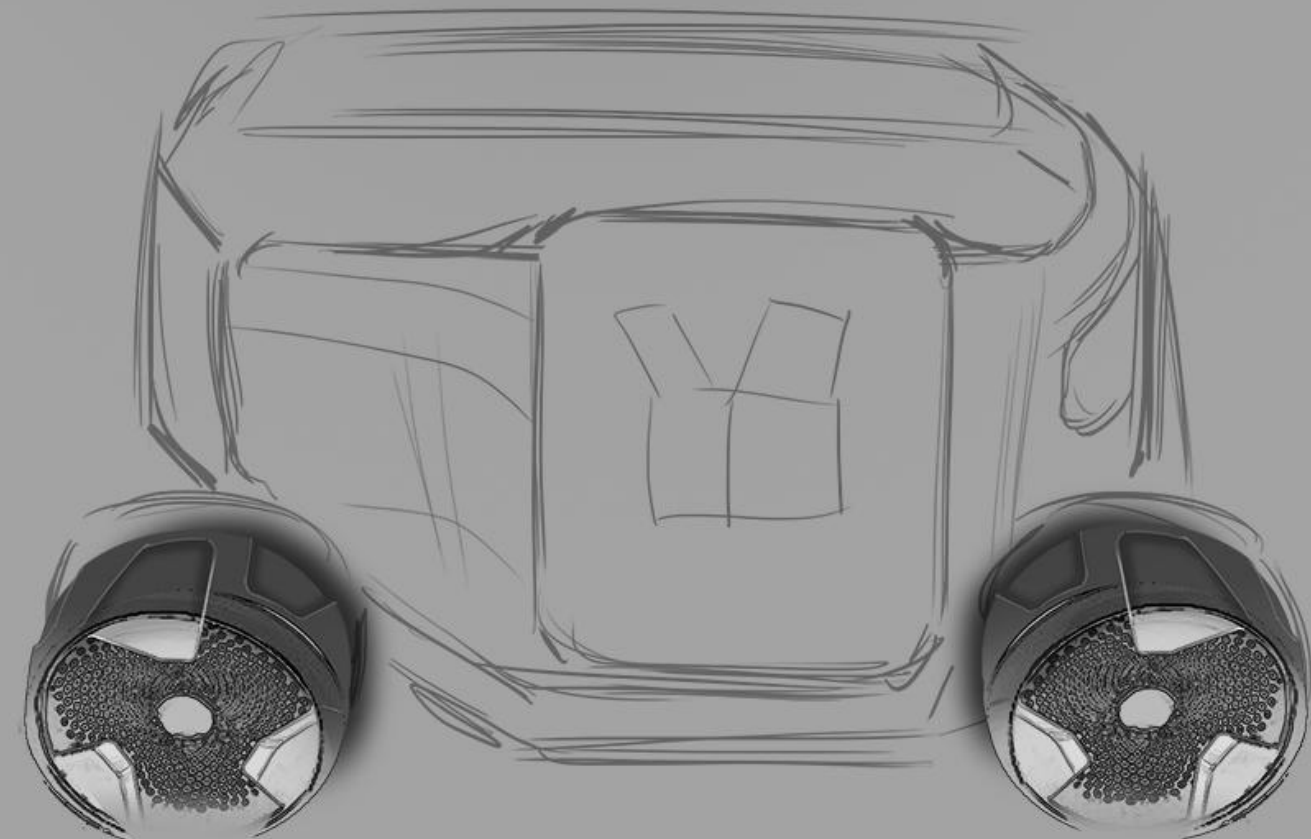
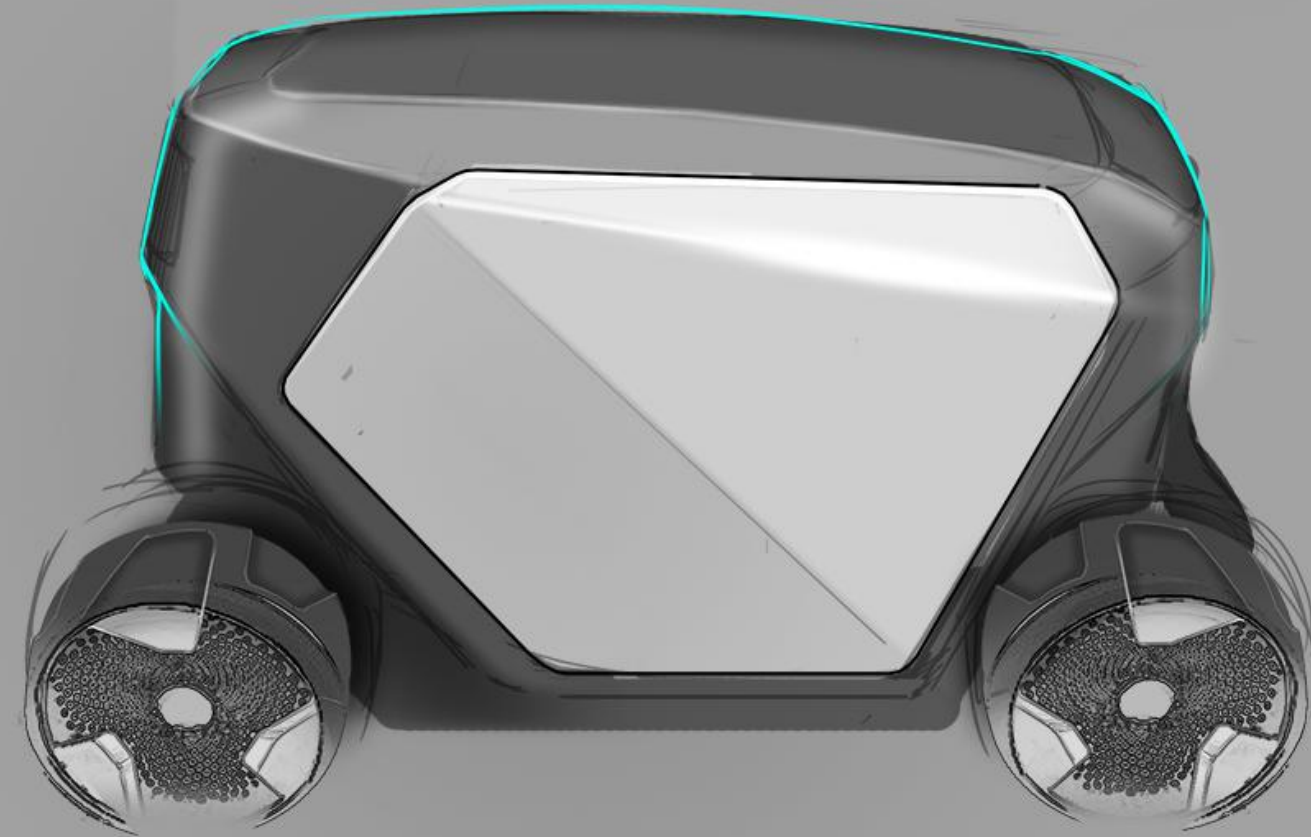
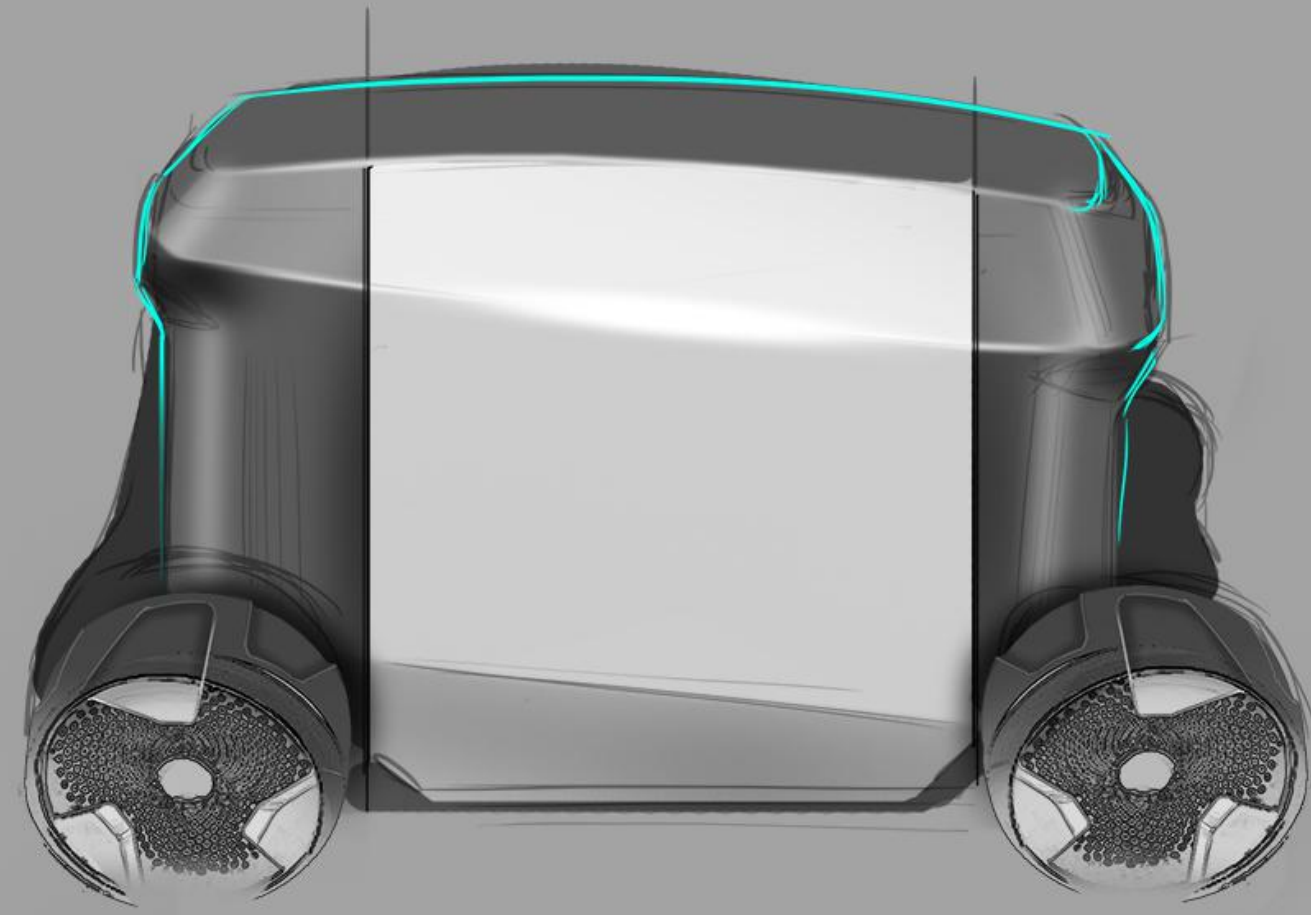

01

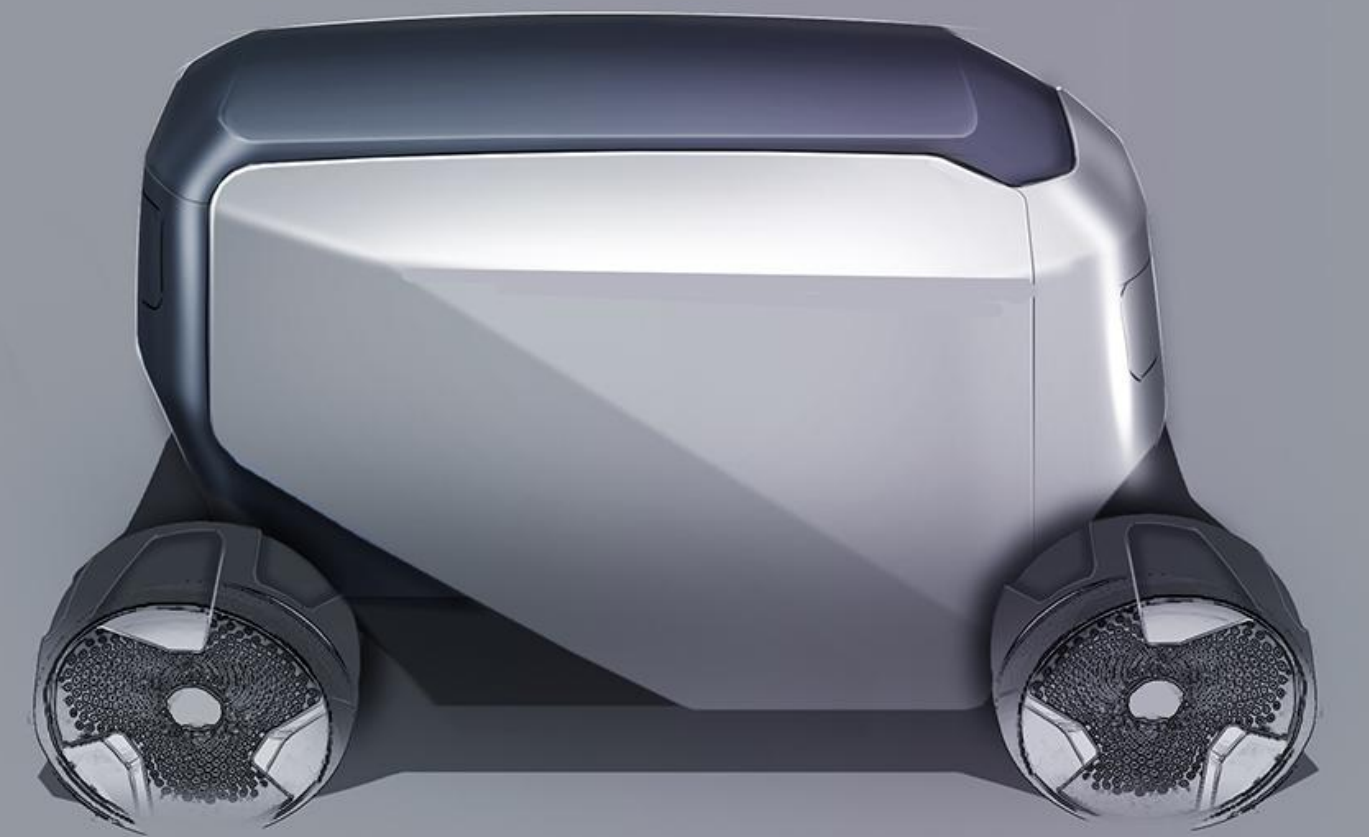

02



03

3D DESIGNS

vision

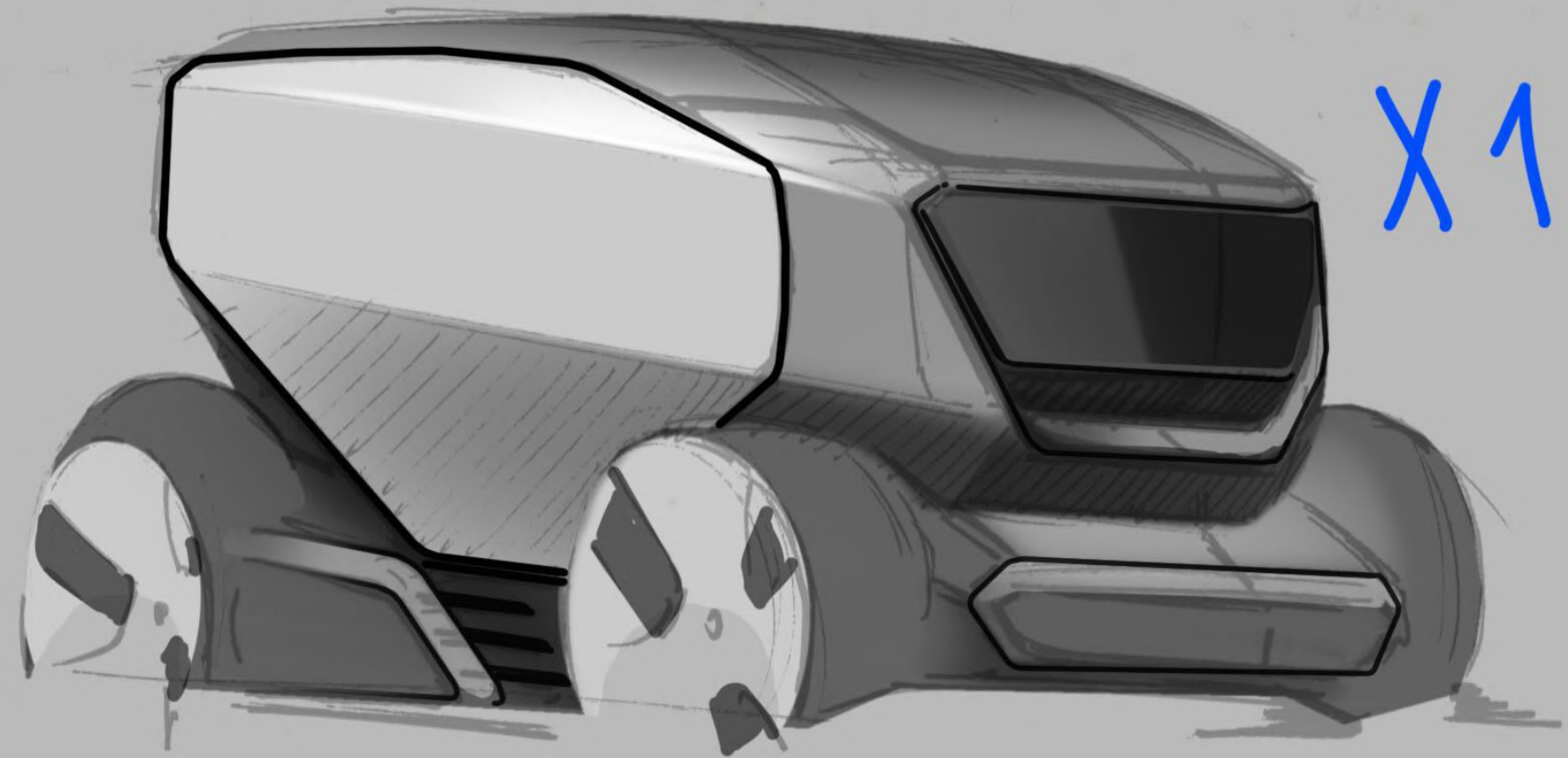

X1

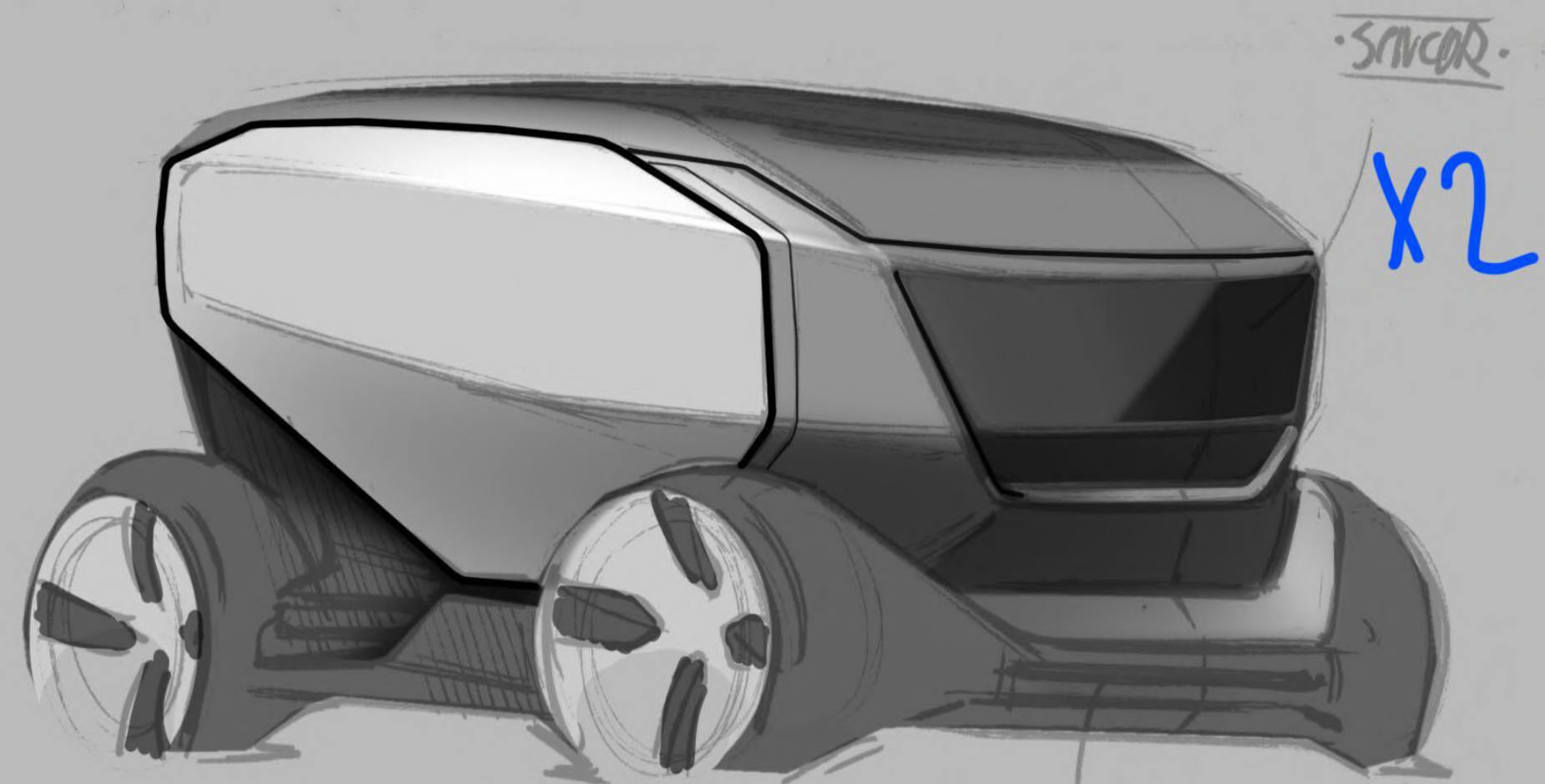

X2

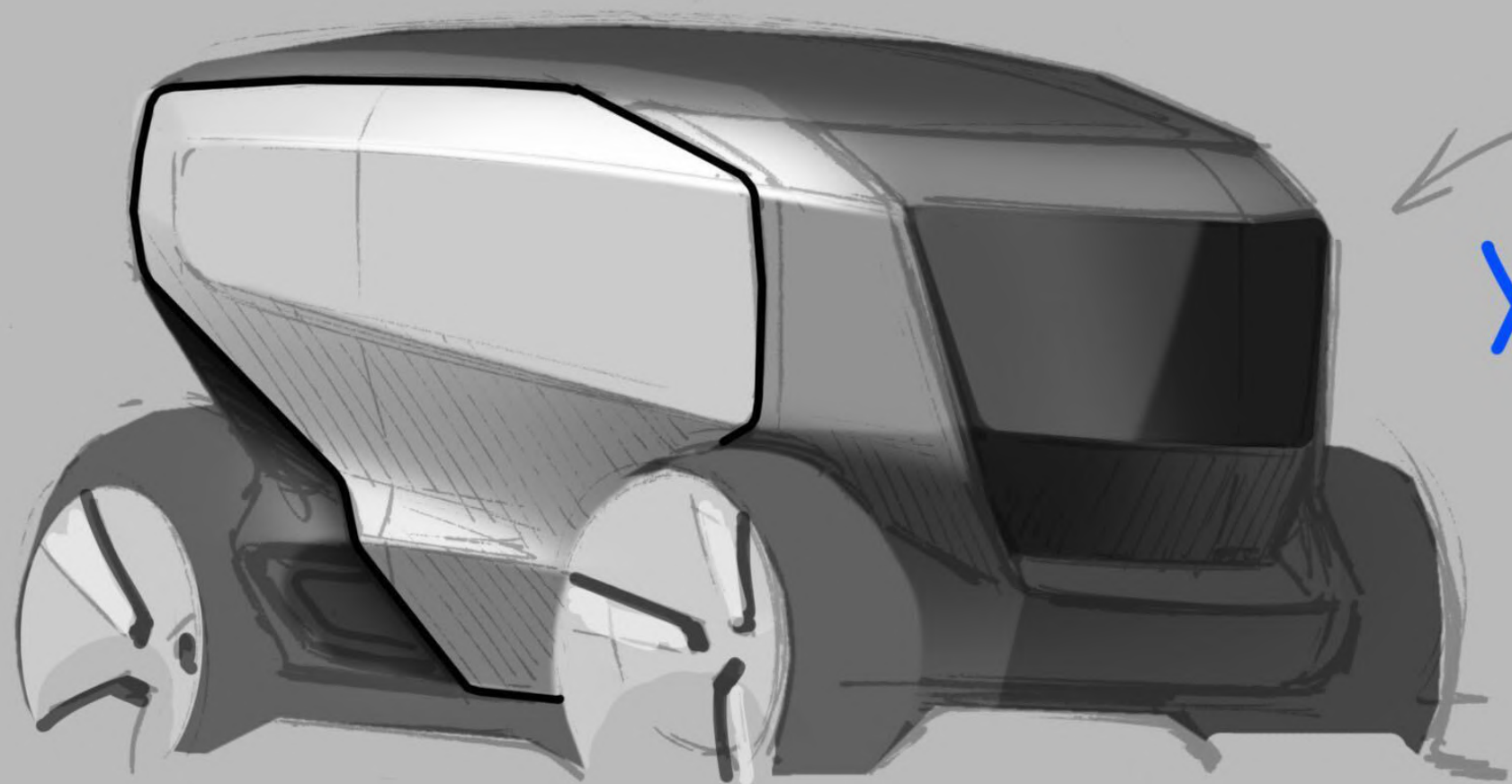

X3

SENSOR

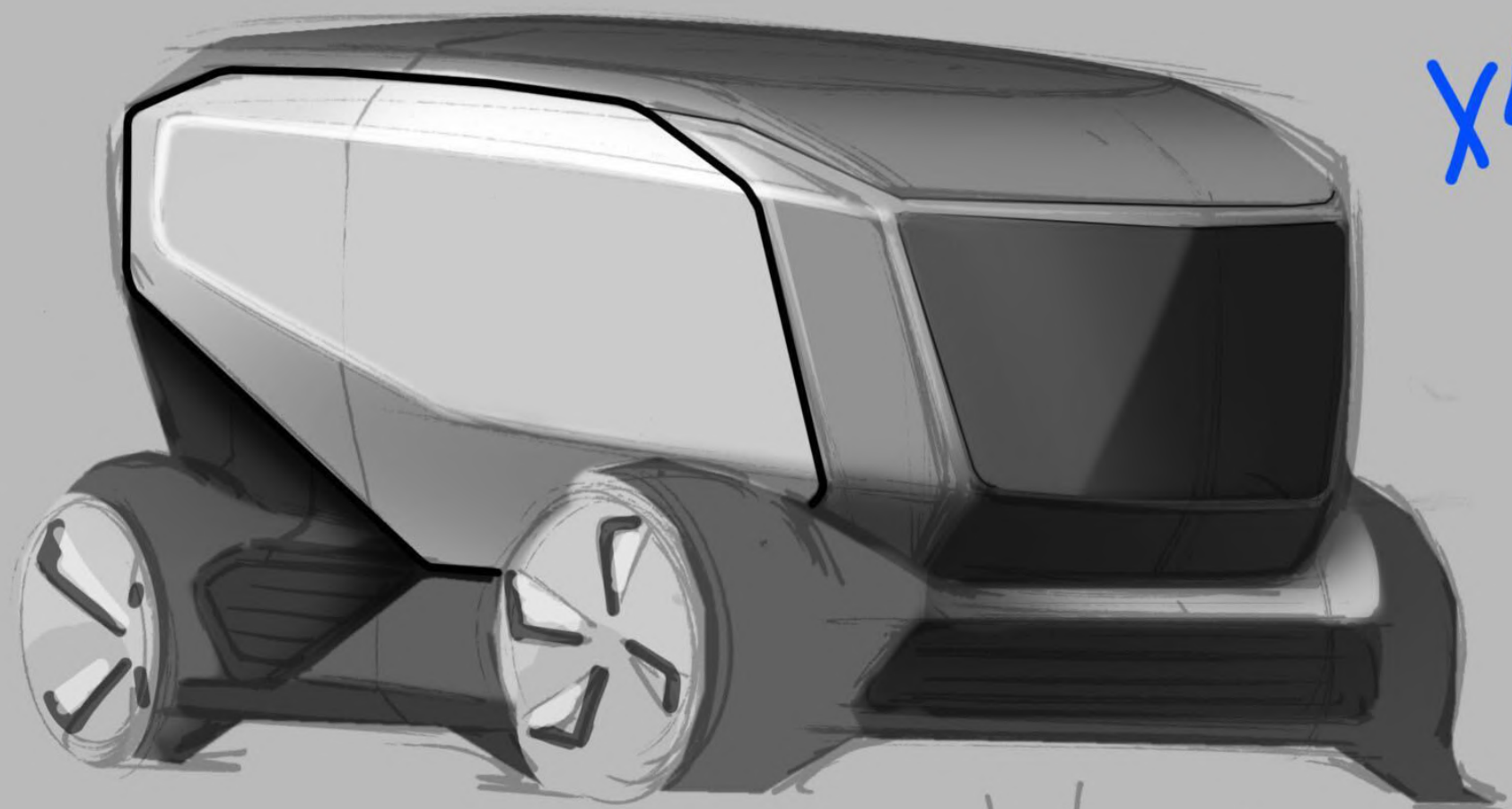

X4

BUMPER

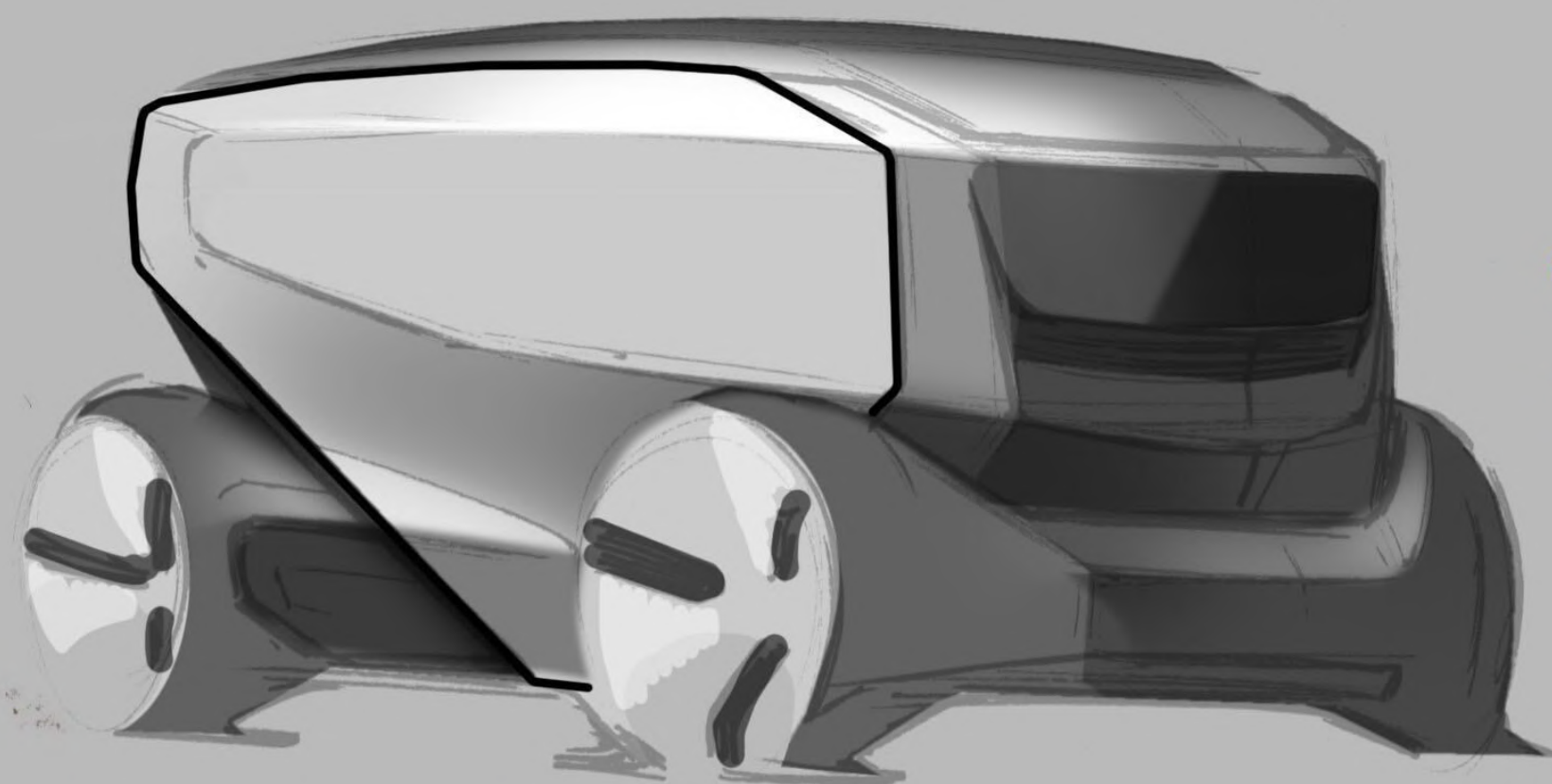

X5



VAN M

PROGRESS

build log

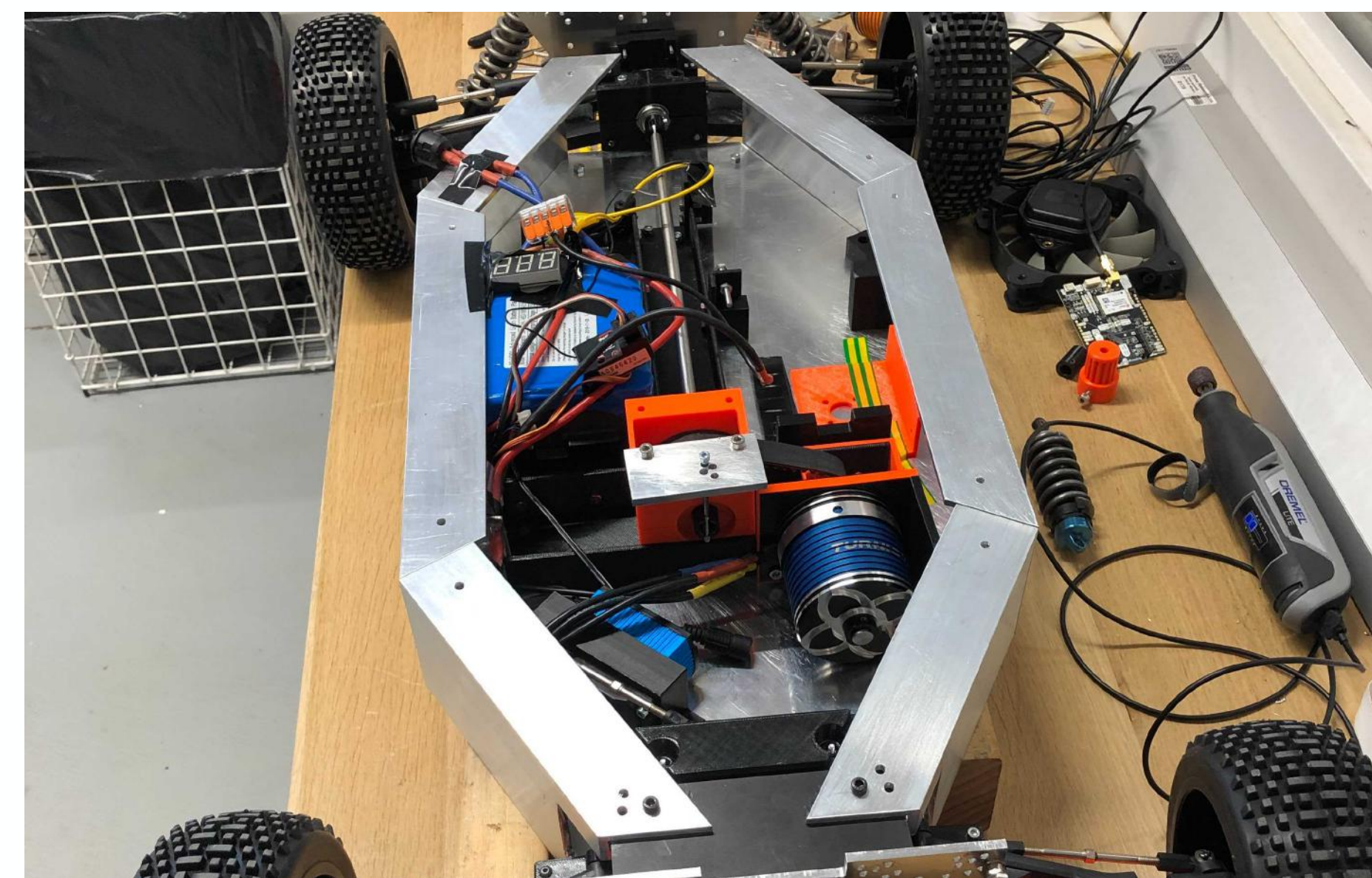
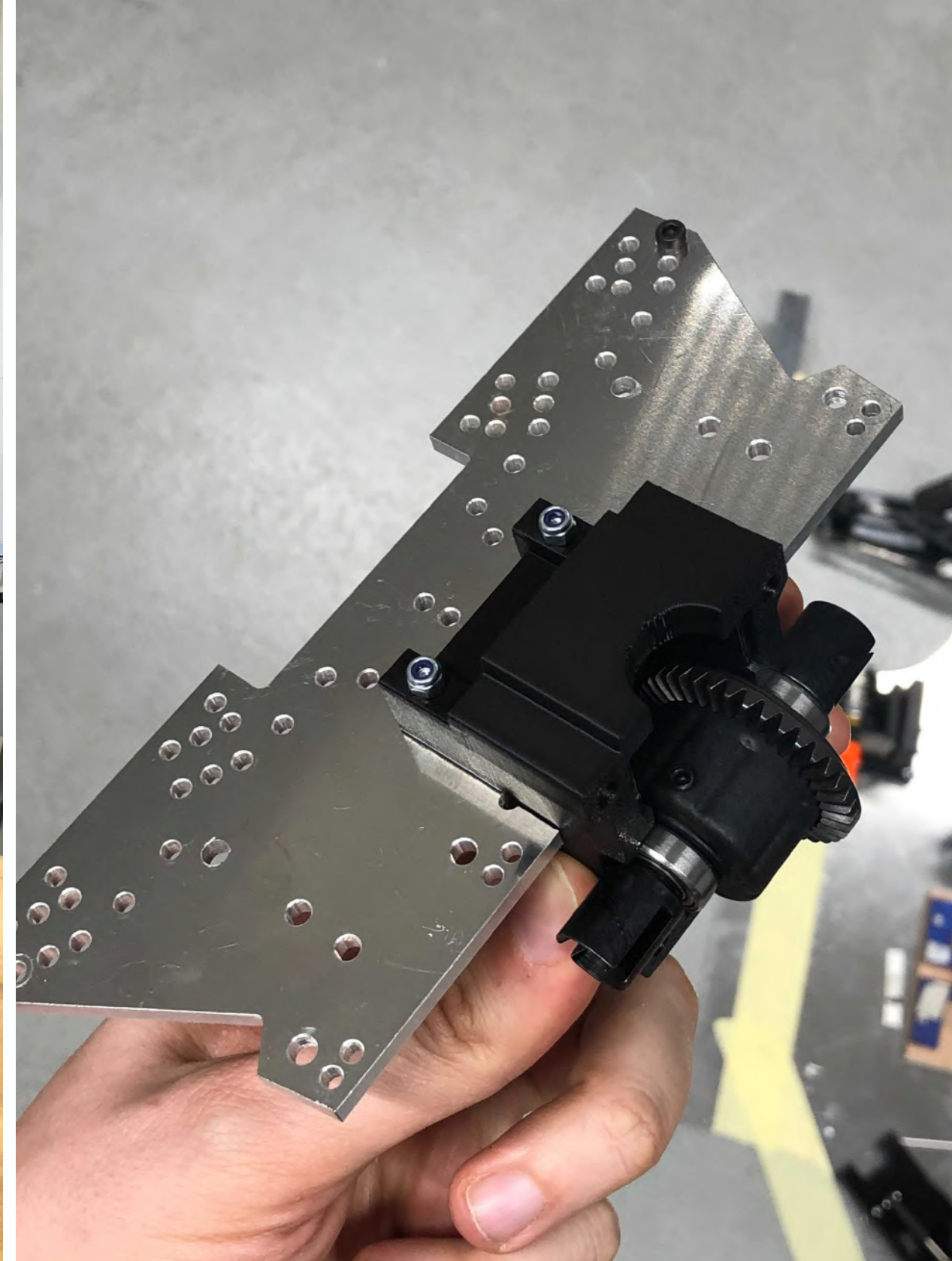
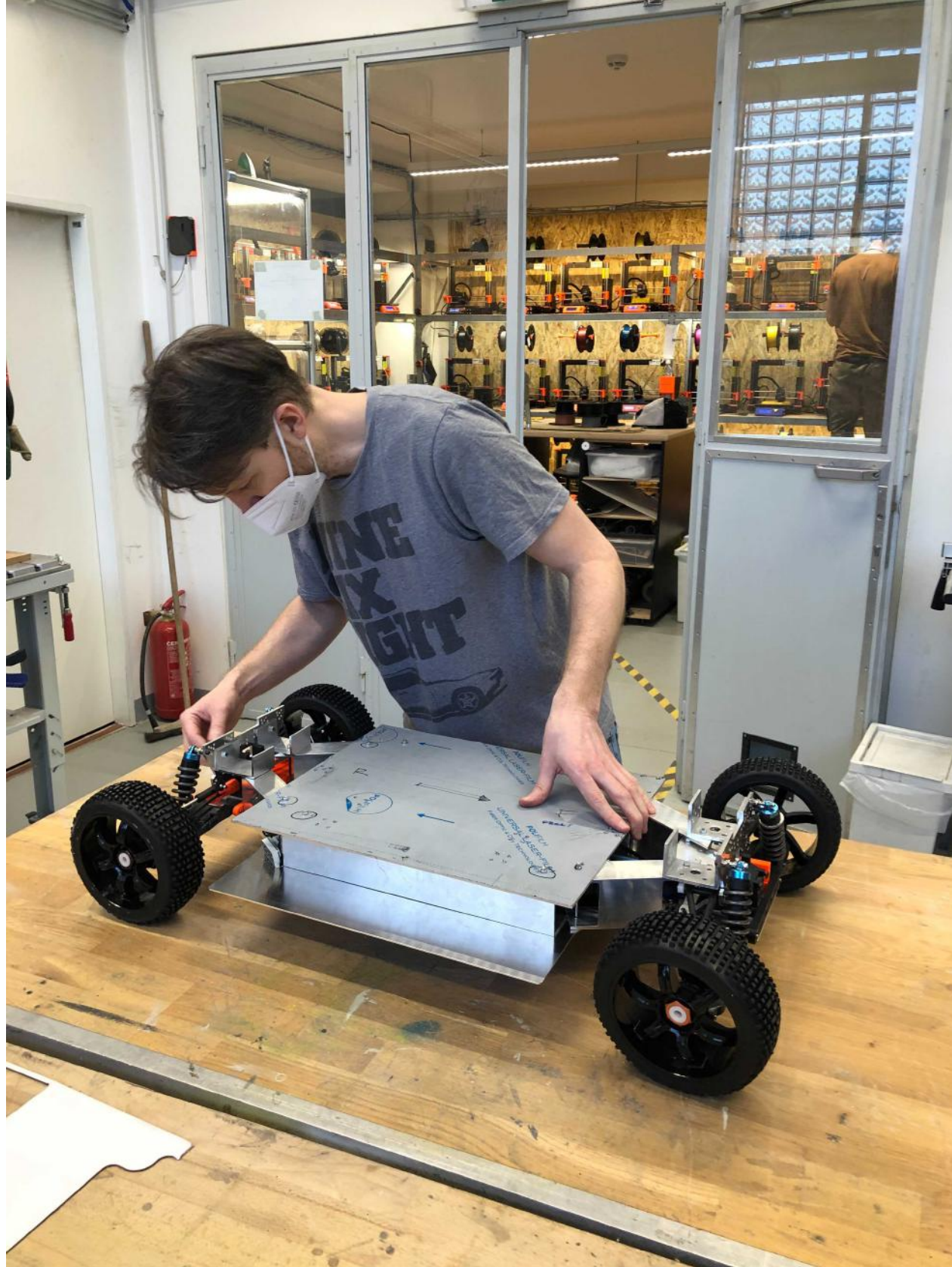



HARDWARE CHASSIS

applications

CO-OPERATION

DEČÍN

Technical university joint operations



VANILLA

tomas krivda tomas@vanilla.cz
jan sedlacek jan@vanilla.cz